

# Operating Manual

Translation of the original



PULVERISETTE 6 *classic line*

**FRITSCH PLANETARY MONO MILL**



Fritsch GmbH  
Manufacturers of Laboratory Instruments  
Industriestraße 8  
D - 55743 Idar-Oberstein

Phone: +49 (0)6784/ 70-0  
Fax: +49 (0)6784/ 70-11  
E-Mail: info@fritsch.de  
Internet: <http://www.fritsch.de>

Fritsch GmbH, has been certified by the  
TÜV-Zertifizierungsgemeinschaft e.V..



TGA-ZM-05-08-00



It was verified through an audit that Fritsch GmbH satisfies the requirements of  
DIN EN ISO 9001:2008.

The enclosed declaration of conformity calls the directives  
which the „PULVERISETTE 6“ corresponds to.  
This permits us to mark the instrument with the CE-Sign.



Instrument number 06.2000.00

Applies as of serial number 1336

## Table of contents

page

<b>1</b>	<b>General Information / Introduction.....</b>	<b>3</b>
1.1	Notes about Operating Instructions.....	3
1.2	Explanations of the signs at the instrument and in the operating instructions.....	4
1.3	Short Description of the Machine.....	5
1.3.1	Applications.....	5
1.3.2	Method of Operation.....	5
1.3.3	Drive Motor and Speed Control.....	5
1.4	Technical Data.....	6
<b>2</b>	<b>Operating Safety.....</b>	<b>7</b>
2.1	General Safety Instructions.....	7
2.2	Operators.....	8
2.3	Protective Devices.....	8
2.4	Danger Points.....	9
2.5	Electrical Safety.....	9
2.5.1	General.....	9
2.5.2	Protection against Restarting.....	9
2.5.3	Overload Protection (see 8 Troubleshooting Checklist).....	9
2.5.4	Unbalance Detection (see 8 Troubleshooting Checklist).....	9
<b>3</b>	<b>Installation.....</b>	<b>10</b>
3.1	Unpacking.....	10
3.2	Transport.....	10
3.3	Erection.....	10
3.4	Ambience conditions.....	11
3.5	Electrical Connection.....	11
3.6	Adaptation to Mains Supply Voltage, Changing Timer and Unbalance Detection in setup mode.....	12
3.7	Switching On for the First Time / Test for Correct Functioning.....	13
<b>4</b>	<b>Working with the Planetary Monomill.....</b>	<b>14</b>
4.1	Choice of Grinding Bowls and Grinding Balls.....	15
4.1.1	Size of the Grinding Balls.....	16
4.1.2	Number of Balls per Grinding Bowl.....	16
4.1.3	Calculated Ball Weight.....	16
4.2	Filling the Grinding Bowl.....	17
4.3	Influencing Quantities During Grinding.....	18
4.3.1	Dry Grinding.....	18
4.3.2	Wet Grinding (Grinding in Suspension).....	18
4.4	Clamping the Grinding Bowls.....	19
4.4.1	Clamping with the "Safe Lock" Holder.....	19
4.4.2	Clamping the 80 ml grinding bowl.....	19
4.4.3	Clamping with Additional Tensioning System.....	20
4.5	Mass Balance.....	21
4.6	Grinding Time.....	21
4.7	Control Panel.....	22
4.7.1	Setting the Speed.....	22
4.7.2	Setting the Running Time.....	22



4.7.3	Reversing Operation .....	22
4.7.4	Repetition of the Grinding / Break Cycles .....	22
4.8	Performing a Grinding Operation .....	23
4.9	Cooling the Grinding Bowls .....	23
4.10	Standby .....	23
4.11	Grinding under protective gas with gas lid .....	24
4.12	GTM System .....	26
<b>5</b>	<b>Cleaning .....</b>	<b>27</b>
5.1	Grinding accessories.....	27
5.2	Mill.....	27
<b>6</b>	<b>Maintenance .....</b>	<b>28</b>
<b>7</b>	<b>Warranty.....</b>	<b>29</b>
<b>8</b>	<b>Troubleshooting Checklist .....</b>	<b>30</b>
<b>9</b>	<b>Examples of Comminution Tasks .....</b>	<b>31</b>
<b>10</b>	<b>Disclaimer.....</b>	<b>33</b>

# 1 General Information / Introduction

## 1.1 Notes about Operating Instructions

- The copyright to these technical documents is the property of Fritsch GmbH, Manufacturers of Laboratory Instruments.
- These operating instructions are not to be reprinted or copied without the express approval of Fritsch GmbH.
- Please study these instructions carefully before operation.
- All operators must be familiar with the contents of the operating instructions.
- Please observe all notes concerning your safety.
- The mill was designed with the user's safety in mind, however inherent risks cannot be excluded. Follow the advices in these instructions to avoid risks to users. The symbols in the right hand margin highlight the risks described in the text.
- Symbols are also to be found on the instrument warning users of possible risks.  
Warning symbols are surrounded by a triangle.
- These operating instructions do not constitute a complete technical description. They describe only the details required for safe operation and maintenance for usage under normal conditions.



*Attention!  
observe operating  
instructions*

## 1.2 Explanations of the signs at the instrument and in the operating instructions

<p>Attention! warning against danger spot observe operating instructions</p>	
<p>Attention! mains voltage</p>	
<p>Attention! risk of explosion</p>	
<p>Attention! hot surface</p>	
<p>Attention! inflammable substances</p>	
<p>Wear protective gloves!</p>	
<p>Wear ear protectors!</p>	
<p>Wear safety goggles!</p>	
<p>Do not step below lifted load!</p>	

## 1.3 Short Description of the Machine

### 1.3.1 Applications

The "pulverisette 6" planetary monomill is universally applicable for quick dry or wet grinding of inorganic and organic samples for analysis, quality control, materials testing and mechanical alloying.

In synthesis, the planetary monomill can be used for mixing and homogenisation of dry samples, of emulsions and of pastes.

### 1.3.2 Method of Operation

The material is crushed and disintegrated in a grinding bowl by grinding balls. The grinding balls and the material in the grinding bowl are acted upon by the centrifugal forces due to the rotation of the grinding bowl about its own axis and due to the rotating supporting disc.

The grinding bowl and the supporting disc rotate in opposite directions, so that the centrifugal forces alternately act in the same and opposite directions.

This results in, as a frictional effect, the grinding balls running along the inner wall of the grinding bowl, and impact effect, the balls impacting against the opposite wall of the grinding bowl.

### 1.3.3 Drive Motor and Speed Control

The machine is driven by a maintenance-free three-phase a.c. motor, which is operated with a frequency converter.

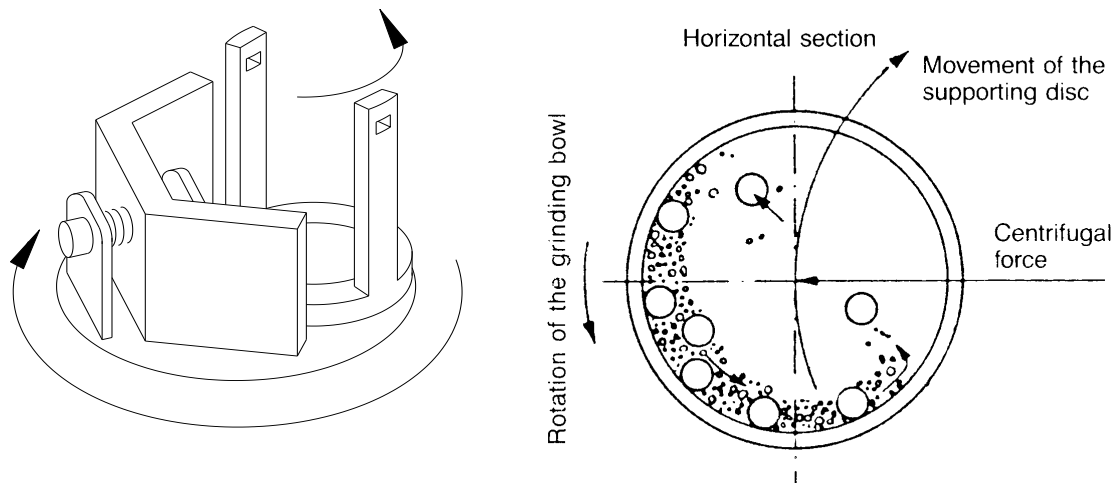

## 1.4 Technical Data

### Dimensions and Weight

Dimensions: 500 x 370 x 530 mm (height x width x depth)

Weight: approx. 67 kg (net), approx. 87 kg (gross)

### Operating Noise

The noise level can be as high as approx. 85dB (A). The value fluctuates greatly depending on the speed, the material being ground and on the type of grinding bowl and grinding balls.

### Voltage

The machine can be operated in two voltage ranges:

- Single-phase alternating voltage 100-120V  $\pm$  10% and
- Single-phase alternating voltage 200-240V  $\pm$  10%.

(see also section Adaptation to Mains Supply)

Transient overvoltages according to overvoltage category II allowed.

### Current Input

The maximum current input is:

voltage range	current input
100 - 120 V	maximum 12 A
200 – 240 V	maximum 7 A

### Power consumption

The maximum power consumption is approx. 1,1kW.

### Electrical Fuses

- Fuse unit at the rear of the machine: 2 x 10 A T
- Miniature fuse 10 A T  
in the frequency converter (remove housing)

### Material

- Maximum feed size approx. 10 mm
- Maximum feed quantity 225 ml

### Final fineness

- Dry grinding  
down to  $d_{50} < 20 \mu\text{m}$  (depending on material)
- Wet grinding  
down to  $d_{50} < 1 \mu\text{m}$  (depending on material)

## 2 Operating Safety

### 2.1 General Safety Instructions

- Read the operating instructions carefully before use.
- The instrument can only be used for the purpose described in Chapter 1.3.1 Applications.
- Use only original accessories and original spare parts. Failure to do so may call into question the performance of the instrument.
- Do not use damaged accessories.
- The operators must be familiar with the contents of the operating instructions.

To this end, for example, the operating instructions must with the instrument.

- Do not remove labels.
- Protective devices must not be made unserviceable or removed.
- Unauthorized modification of the instrument or any part thereof will result in the loss of the conformity to European directives which is asserted by Fritsch and the warranty.

- Wear protective gloves!  
Grinding bowls may be very hot after grinding.
- Wear safety glasses  
Wet grinding may cause high pressure in the grinding bowl- Danger of squirting!

- Wear ear protectors - noise level up to 85dB(A).
- Don't run the instrument several hours without cooling phases - Danger of overheating.
- Behaviour at all times must be such as to strictly preclude any accidents.
- Furthermore, the MAC values at place of work specified in the pertinent safety regulations must be adhered to. Where applicable, ventilation must be provided or the instrument must be operated under an exhaust hood.

- When oxidizable materials such as metals, organic materials, wood, coal, plastic, etc. are ground or sieved, the risk of spontaneous ignition (dust explosion) exists whenever the fine particles exceed a specific percentage. While such materials are being ground, it is therefore necessary to take special safety precautions (e.g. wet grinding) and the work must be supervised by a specialist.
- The instrument is not explosion-proof and is unsuitable to grind or sieve materials which are explosive, combustible or promote combustion.

- Do not allow the planetary monomill to run unsupervised. Due to the vibrations, under certain operating conditions, the machine may creep along the surface on which it is located or mounted.



Observe operating instructions!!



Wear protective



Wear safety goggles!



Wear ear protectors!



Attention! risk of explosion

## 2.2 Operators

- No one other than authorized persons should operate the instrument and it must be serviced and repaired by trained specialists.
- No one suffering from medical problems or under the influence of medications, drugs, alcohol or overtiredness should be permitted to operate the instrument.

## 2.3 Protective Devices

**Protective devices should be used for the intended purpose and must not be made unserviceable or removed.**

**All protective devices should be regularly checked for completeness and to ensure that they are functioning correctly. See section Maintenance.**

The hood must be closed when the machine is started up.

The hood is locked:

- when the machine is disconnected from the mains supply
- during operation

**The hood can be opened only when the drive of the mill has come to a standstill.**

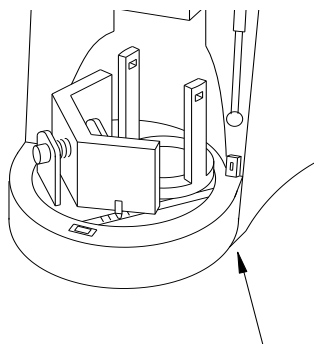

### Opening the hood when the machine is disconnected from the mains supply

- Insert the attached triangular wrench through the bore, and turn clockwise.
- The closure hatch can now be opened after the spring-loaded lock at the front of the hood is opened.
- The planetary monomill can now not be switched on. If it is to be switched on, the safety lock must be activated by turning the triangular wrench anticlockwise, and the hood must be closed.

## 2.4 Danger Points

- Danger of crushing when the hood is being closed.
- Danger of crushing at the grinding bowl holder.
- Danger of crushing at the unbalance compensation.

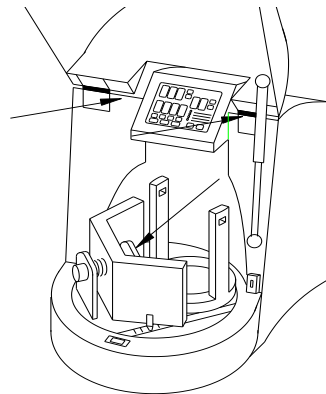

Attention!

## 2.5 Electrical Safety

### 2.5.1 General

- The main switch disconnects the machine from the mains supply at two poles.
- Switch off the main switch if the planetary monomill is to be inoperative for an extended period (e.g. over night).

### 2.5.2 Protection against Restarting

In the event of a mains failure during operation or after switching-off with the main switch, the hood will remain locked. When the mains voltage is restored, the lock of the hood will open. For safety reasons, however, the planetary monomill will not start again.

### 2.5.3 Overload Protection (see 8 Troubleshooting Checklist)

In the event of overloading, the speed of the machine will be reduced. This is indicated by the REDUCED SPEED light being illuminated.

If the drive motor overheats, the machine will switch off.

If the drive is obstructed, the machine will switch off.

### 2.5.4 Unbalance Detection (see 8 Troubleshooting Checklist)

In the event of an excessive unbalance, the machine will switch off.

## 3 Installation

### 3.1 Unpacking

- Open the bandages with which the hood is fastened on the transport pallet. The hood is a wooden box placed over the transport pallet.
- Lift the hood off the transport pallet.
- The cellular parts can be removed now or during the installation. To ease this removal you can break the performatated segments.
- Check that the items supplied correspond to your order. Grinding bowls of hardened steel may exhibit surface indentations caused by the manufacturing process. These do not influence the grinding or the grinding result and generally disappear after the first grinding. When present, these surface indentations lie within the permissible manufacturing tolerance ranges. Accordingly, complaints regarding such grinding bowls cannot be accepted.
- Please store the transport packing carefully to use it again in case of an eventual return of the instrument. Fritsch GmbH does not bear the risk of damages depending on improper packings (non-Fritsch packings).

### 3.2 Transport

- Transport the planetary monomill on the transport pallet with a fork lift truck or a hand fork lift truck.
- To carry the machine, grip it below the edge of the housing.



*Do not step below lifted loads!*

**Carrying the machine will require at least two persons.**

### 3.3 Erection

- Lift the planetary monomill off the transport pallet.

**Lifting the machine down will require at least two persons.**

- If the cellular parts have not yet been removed, this can be done now. See chapter 3.1 Unpacking.
- Place the planetary monomill on a level, stable surface (table.....). To ensure that the mill rests securely and to prevent "walking" during operation, a fastening set is supplied with the device. Screw the two rings to an appropriate surface with the help of the drilling jig. Place the mill on the surface with the 2 feet of the device in the corresponding rings.



**It is inadvisable to operate the planetary monomill while it is standing on the transport pallet.**

- Ensure that there is good access to the planetary monomill. There must be enough space to reach the main switch.
- Do not block the exit of air from the ventilator louver at the side. There is a danger of overheating if the louver is blocked.

### 3.4 Ambience conditions

- Use the instrument only inside.
- The air must not contain any electrical conductive dust.
- The ambient temperature must be between 5 and 40°C.
- Height up to 2000m M.S.L.
- Maximum relative humidity of air 80% temperature up to 31°C, linear decreasing down to 50% relative humidity of air at 40°C
- Contamination level 2 (IEC 664)

### 3.5 Electrical Connection

**DANGER****Electrical Safeguard!**

Danger of damages due to short-circuit.

- Ensure that the socket is connected to a power line secured with a circuit breaker.

Before making the connection, compare the voltage and current values shown on the nameplate with the values of the mains supply to which the instrument is to be connected.

Single-phase alternating voltage with protective conductor (see section 1.4).

**Caution**

Non-observance of the values on the type plate may damage electrical as well as mechanical components.

**DANGER****Mains voltage!**

The connector cable may only be altered by a trained expert.

### 3.6 Adaptation to Mains Supply Voltage, Changing Timer and Unbalance Detection in setup mode

The voltage range of the machine should be switched over only by specialist staff.

#### Adaptation to Mains Supply Voltage in setup mode

1. Disconnect the machine from the mains supply.
2. At the rear of the machine, set the changeover switch to the voltage range.
3. Connect the machine to the mains supply.
4. Press and hold down the STOP button on the control panel at the front.
5. Switch on the main switch at the rear of the machine and release the STOP button immediately afterwards.
6. The POWER SUPPLY light is flashing → **setup mode**  
The POWER SUPPLY light is not flashing, repeat the procedure
7. With the + / - ROTATIONAL SPEED buttons, select the mains supply voltage level (**90 - 260 V**).
8. To store the settings and end the **setup mode**, press the STOP button.

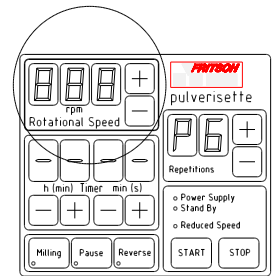

#### Further options in setup mode

- A unbalance detection on / off:  
 operate (right) - button in the TIMER panel  
 unbalance detection on: display: -  
 unbalance detection off: display: 1
- B timer function hours, minutes / minutes, seconds:  
 operate (right) + button in the TIMER panel  
 Hours and minutes: display: -  
 Minutes and seconds: display: 1

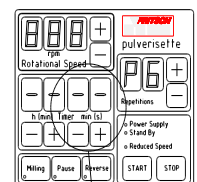

Switching off the unbalance detection at own risk!  
 See chapter 2 Operating Safety.

Pressing the REPETITIONS buttons in setup mode alters the machine type. Do not change anything here: P6 should be indicated in the display. Otherwise, damage will occur during operation.

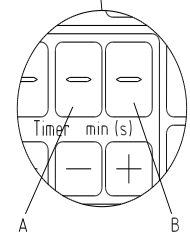

### 3.7 Switching On for the First Time / Test for Correct Functioning

Switch on the machine only when all the work described in section 3 on Installation has been done.

#### Switching On

1. Connect the machine to the mains supply.
2. Switch on the machine with the main switch at the rear.
3. The POWER SUPPLY display will come on.
4. Open the hood.
5. If the grinding bowl holder or any wood are present, take them out.  
There should be nothing in the grinding bowl holder.
6. Move the counterweight in fully.
7. Close the hood.
8. Set the speed to 100 on the control panel.
9. Press START on the control panel.
10. The hood will be locked and the mill will run at the preselected speed.

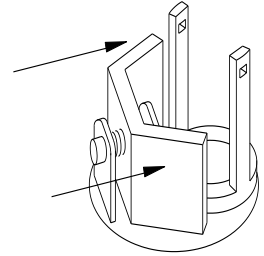

**Perform this test at a speed of not more than 100 rpm, and make sure to move the counterweight in fully, as an excessively large unbalance will otherwise occur.**

#### Switching Off

- Press STOP on the control panel.
- After a short period (after the mill has come to a standstill), the hood is unlocked and can be opened.

## 4 Working with the Planetary Monomill

### Warning!!!

Before starting the machine, ensure that the grinding bowl is correctly braced and there are no loose parts inside the device. There is a risk that loose grinding bowls or parts will be thrown out. → □ If this instruction is not observed, no guarantee or claims will be accepted for damages to the device or injuries to persons.

### Caution!!!

The grinding tools are subject to normal wear. Prior to each comminution the thickness of the grinding bowl wall is to be inspected. With severe wear the grinding bowl is to be changed. If not, the possibility exists that the grinding ball due to high centrifugal forces which occur during the grinding may strike through the grinding bowl wall, damaging the mill. We don't honour the warranty or accept complaints for instrument damage or personal injuries occurring when disregarding the above information.

### NOTE



During milling, high temperatures can build up in the grinding bowl.

In encased grinding bowls, the inserts are glued into the casing with a two-component construction adhesive.

The adhesive is temperature-resistant up to approx. 140°C. Above 140°C, the adhesive becomes liquefied and collects below the insert in the casing. When the adhesive cools down, it solidifies again and presses the casing upward. As a result, the insert could get damaged. This always makes the grinding bowl unusable.

At temperatures above 200°C, the adhesive is ruined. The same applies for encased grinding bowl lids.

## 4.1 Choice of Grinding Bowls and Grinding Balls

### Caution!!!

No warranty or claims shall be accepted in case of damages caused on account of using grinding bowls and grinding balls that are not original accessories of the appliance.

In order to prevent excessive abrasion, the hardness of the grinding bowl used and of the grinding balls must be higher than that of the material used.

Material (bowl and balls)		density* in g/cm <sup>3</sup>	restistance to abrasion
Agate	(99.9% SiO <sub>2</sub> )	2.65	Good
Sintered corundum	(99.7% Al <sub>2</sub> O <sub>3</sub> )	3.8	Fairly good
Zirconium dioxide	(95% ZrO <sub>2</sub> )	5.7	Very good
Stainless steel	bowl: (17-19% Cr + 8-10% Ni) ball: (12,5-14,5% Cr + 1% Ni)	7.8	Fairly good
Tempered steel	bowl: (11-12% Cr) ball: (1,0-1,65% Cr)	7.9	Good
Tungsten carbide	(93%WC+6% Co)	14.7	Very good
Silicon nitride (Syalon)	(90% Si <sub>3</sub> N <sub>4</sub> )	3.1	Extremely good

The grinding bowls and grinding balls of zirconium dioxide are resistant to acids with the exception of hydrofluoric acid.

Normally, grinding bowls and grinding balls of the same material should be chosen.

Exeption: Tungsten carbide balls (<20mm) may be combined (just a few minutes) with steel bowls.

\*High density means high impact energy

### 4.1.1 Size of the Grinding Balls

Type of feed material	Ball diameter
Hard samples feed particle size <10 mm	30 mm or 40 mm
Medium piece size (<5 mm)	20 mm
Fine material (0.5 mm)	10 mm or 5 mm
Homogenisation of dry or liquid samples	10 mm
Homogenisation of viscous samples	20 mm

**This are just clues: the size of the grinding bowls and grinding balls should be determined experimentally if necessary.**

**Attention:**

**Mixing balls with different diameters is not recommended.**

**(If different ball diameters are used there is the danger of higher abrasion of the balls!)**

### 4.1.2 Number of Balls per Grinding Bowl

A larger number of balls reduces the grinding time, and the grinding result will lie within a narrower grain band width.

Ball Ø (mm)	Grinding bowl volume (ml)	80	250	500
5	Number of balls (piece)	250 - 300	1200 - 1300	2000 - 2500
10	Number of balls (piece)	25 - 30	50 - 150	100 - 250
15	Number of balls (piece)	10	45 - 50	70 - 100
20	Number of balls (piece)	5	15 - 20	25 - 35
30	Number of balls (piece)		5 - 6	10
40	Number of balls (piece)			4

**These values are just clues: the number of balls should be determined experimentally if necessary.**

**While using balls with diameter Ø 30 and Ø 40 mm please look after the unit permanently, because the vibrations could cause the machine to move around.**

**Balls with a diameter of 40 mm are rarely used for grinding, because this ball size can quickly cause damage to the grinding bowl if the grinding duration is too long. Only use grinding balls of this diameter for brief grinding durations.**

### 4.1.3 Calculated Ball Weight

Ball diameter in mm		5	10	15	20	30	40
Material	density in g/cm <sup>3</sup>	Calculated ball weight in g					
Agate	2,65	0,17	1,39	4,68	11,10	37,46	88,80
Sintered corundum	3,8	0,25	1,99	6,72	15,92	53,72	127,34
Zirconium oxide	5,7	0,37	2,98	10,07	23,88	80,58	191,01
Stainless steel	7,8	0,51	4,08	13,78	32,67	110,27	261,38
Tempered steel	7,9	0,52	4,14	13,96	33,09	111,68	264,73
Hardmetal tungsten carbide	14,7	0,96	7,70	25,98	61,58	207,82	492,60

To calculate the weight of the required balls, the “calculated ball weight” is multiplied by the “number” of balls needed.

Example: A 250 ml agate bowl must be filled with 1221 agate balls of 5 mm diameter.

Calculation: 0.17 g \* 1221 balls ≈ 208 g

208 g of grinding balls can be weighed out and placed in the grinding bowl; this saves the time required for counting out the balls.

## 4.2 Filling the Grinding Bowl

It is imperative that the following sequence be observed:

1. Place the grinding balls in the empty bowl.
2. Fill the material to be ground on top of the balls

**Never use the mill without sample material!  
Danger of badly damage of the grinding balls and bowl!**

Grinding bowl	min. material volume	max. material volume
500ml	80ml	225ml
250ml	30ml	125ml
80ml	1ml	30ml

**Using less sample material than recommended will cause higher abrasion!**

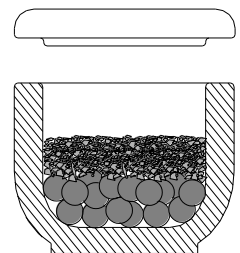

Filling the grinding bowl

## 4.3 Influencing Quantities During Grinding

### Running time (grinding time)

A longer grinding time will increase the fine fraction. To reduce the grinding time you can use grinding bowls and balls with a higher density and therefore with a higher impact energy.

### Speed

A higher speed will reduce the grinding time and increase the fine fraction.

### Reversing operation (regular reversal of the direction of rotation)

- useful for mechanical alloying
- improves homogenizing of the material

### Number and size of the balls

Pregrinding coarse, hard material with large balls:  
small fine fraction.

Use of many small balls will increase the fine fraction if the running time is increased.

### Mass of the balls (type of material)

A higher mass (spec. weight) of the grinding balls will accelerate the grinding.  
(see the table in section 4.1 on Choice of Grinding Bowls and Grinding Balls)

#### 4.3.1 Dry Grinding

Below a particle size of approx. 20  $\mu\text{m}$ , surface forces predominate and the material will start to "stick".

Further dry grinding can be achieved if surface-active substances are added to the material.

Examples (maximum quantity to be added in % by mass)

- Stearic acid 2-3%
- Aerosil (microdispersed silicic acid) 0.5-2%
- Silica sand ~ 2%
- Glass powder ~ 2%

#### 4.3.2 Wet Grinding (Grinding in Suspension)

When grinding in suspension, you can add auxiliary substances in liquid form with a high boiling point and low vapour pressure.

Flammable liquids with a boiling point  $<100^{\circ}\text{C}$  should not be used.

Add enough fluid until you have a suspension that is similar to motor oil. If the suspension is too thin, then the particles flow off the ball's surface and the grinding effect is not optimal. If the suspension is too thick, then the balls cannot work and the grinding effect is also not satisfactory.

The viscosity needs to be checked often during grinding.



Attention!  
inflammable  
substances

## 4.4 Clamping the Grinding Bowls

### 4.4.1 Clamping with the "Safe Lock" Holder

The following tests should be performed before the grinding bowls are clamped in the machine before each grinding operation:

- Is the black rubber disk inserted in the bowl holder? Rough side up! (Check before first run)
- Check the rubber disc in the bowl holder for damage.  
Replace rubber discs that are flattened.
- The flat Teflon seal (for sealing between the lid and the bowl) must not be damaged or dirty.  
Replace severely deformed flat Teflon seals.
- The surfaces of the lid and of the bowl on which the flat Teflon seal rests must be clean.
- Check the rubber disc at the safelock for damage.  
Replace rubber discs that are flattened and project laterally beyond the pressure piece.

### Clamping

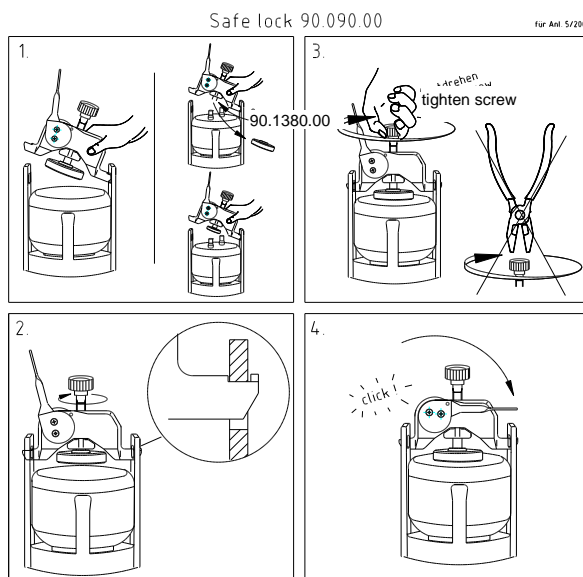

After a few minutes of grinding, and in the cooling phases, check that the clamping is secure.

### 4.4.2 Clamping the 80 ml grinding bowl

- Either use the 80 ml with the reducing piece fitted (order no. 90.1120.09) or
- Use two 80 ml grinding bowls, one on top of the other.

### 4.4.3 Clamping with Additional Tensioning System

Grinding bowls can be filled and then closed with the help of the Additional Tensioning System in a box with protective gas, without being clamped in the mill.

It's also possible to clamp the gas lids with the Additional Tensioning System. So they can be filled with protective gas out of the mill.

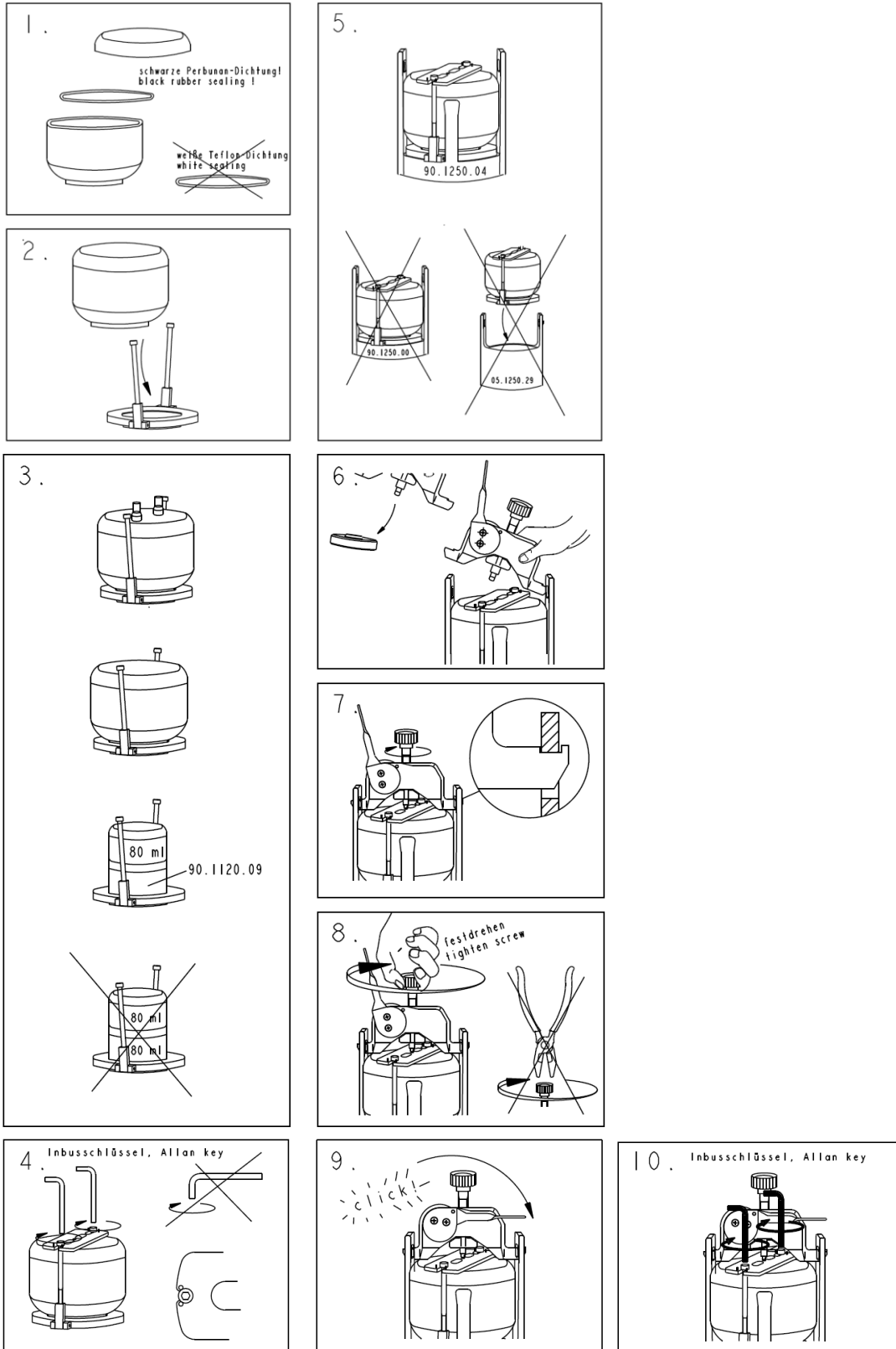

## 4.5 Mass Balance

In order to compensate for the unbalance, the counterweight should be positioned in accordance with the scale (right).

The weight indicated on the scale is the weight of the filled grinding bowl with lid.

**If heavy bowls are used and/or high speed is set an adjustment of the mass balance may be necessary.**

### CAUTION

**Additional weights like „GTM“ and “additional tensioning system” must also be balanced.**

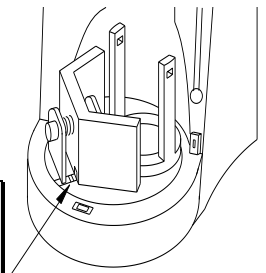

## 4.6 Grinding Time

In accordance with the application, the grinding time should be adapted to the heating of the bowl. The temperature inside the bowl is about 20-30°C higher than the outside of the grinding bowl.

**The max. temperature at the outside walls of the bowl is about 100-110°C (Agate max. 70-80°C). The grinding time is determined by this temperature. The grinding time which does not exceed this temperature depends on the sample material, the balls and the speeds. For this reason the grinding time has to be determined experimentally by the user.**



Attention! hot surface of grinding bowl

### clue

In the case of grinding at high speeds and with large bowls, the grinding time should not exceed 1 hour (temperature-dependent). Then allow to cool for 0.5 to 1 hour.

- Pay attention to the heating of the material;
- In the case of extended running times, if necessary set a break time for cooling.
- Before switching on again after a cooling phase, check that the clamping is secure.

To shorten the grinding time you can use grinding bowls and balls with a higher density and therefore with a higher impact energy.

In the case of operation for mixing and homogenisation at low speeds, the mill may run for several hours without harm being done.

The machine cannot be operated with an external timer.

## 4.7 Control Panel

- Switch on the main switch at the rear of the machine.
- The POWER SUPPLY display will light up.

### 4.7.1 Setting the Speed

→ ROTATIONAL SPEED control panel area

Press or press and hold down the + or - button.

The speed can be selected in steps of 10 rpm between 100 rpm and 600 rpm.

During operation, the actual speed is indicated;

pressing the + or - button will cause the specified speed to be shown temporarily.

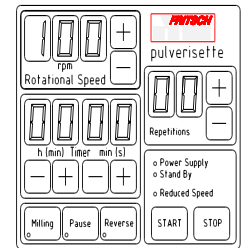

### 4.7.2 Setting the Running Time

→ TIMER control panel area

- Press the MILLING button.  
The button will light up.  
Press the + or - button and select the running time in hours (0..99) and minutes (0..60).
- Set a break time if this is required for cooling.  
Press the "Pause" button.  
The button will light up.  
Press the + or - button and select the break time in hours (0..99) and minutes (0..60).  
If no break time is required, set the break time to 0.

#### Notes:

- If the combination minutes/seconds instead of hours/minutes was set in the set-up mode (section 3.6), the **h** numbers indicate the minutes and the **min** numbers the seconds.
- During operation, the remaining running times and the remaining break times are indicated.
- The machine cannot be operated with an external timer.
- For information on running times, see section Grinding Time
- To interrupt the grinding, press the STOP button; continue grinding by pressing the START button, n.b. account is taken of the grinding time already elapsed and of the number of repetitions.

### 4.7.3 Reversing Operation

→ Press the REVERSE button.

The direction of rotation of the planetary monomill will now be changed after the chosen running time has elapsed. For this function REPETITIONS is set to minimal 1.

### 4.7.4 Repetition of the Grinding / Break Cycles

→ Repetitions control panel area

Press the + or - button and choose the number of repetitions (0..99). During operation, the number of the remaining cycles is indicated.

## 4.8 Performing a Grinding Operation

- After everything has been set up as described in section 4 on Working with the Planetary Monomill, close the hood.
- Press the START button on the control panel.
- The hood will be locked and the planetary monomill will run.
- The planetary monomill will rotate at the speed set (set speed) – if the load is too great, e.g. if the grinding bowl is too large, the machine will be run at a lower speed (actual speed) so as to prevent overloading.

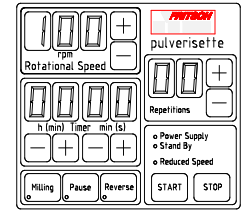

If the planetary monomill does not start, see the Troubleshooting Checklist in section 8.

### Overloading

In the event of overloading of the planetary monomill, the speed will be reduced and the REDUCED SPEED light will shine.

If it is overloaded for a prolonged period, the mill will switch off; see the Troubleshooting Checklist in section 8.

### Miscellaneous

During operation, the hood will remain locked even during the breaks, and the fan will run.

### Switching Off

- Press STOP on the control panel.
- When the drive has come to a standstill, the hood is unlocked and can be opened.
- Switch off the main switch at the rear of the machine if the machine is to be inoperative for an extended period.

#### NOTE



At the very first time, a running in time is needed. This ascertain later a full power and rotation. If you do not do that, it could be possible that during the first grindings, the mill don't work with the optimal rotation when you use heavy loaded grinding bowls. In fact you have to run in the new mill for 1 – 2 hour to get the required rotation speed!

## 4.9 Cooling the Grinding Bowls

- with the hood open or
- at the programmed break times with the hood closed (locked) and the ventilator running.



Attention! hot surface of grinding bowl

## 4.10 Standby

After one hour, if the mill is not being operated and the hood is open, the mill will switch to the energy-saving standby mode. The STAND BY light will come on.

The standby function will not be activated when the hood is closed.

## 4.11 Grinding under protective gas with gas lid

### NOTE



All our gas lids are subjected to a bubble test (Werker water bath test, approved test method): The part under inspection is sealed, pressurized to 5.5 bar and submerged in a water basin. If there is a leak, bubbles will form. The bubbles that form within a certain period of time are evaluated by the operator/inspector.

Only gas lids with leak rates  $<10^{-4}$  [mbar l/s] receive approval.

**Important! compensate any unbalance  
see chapter 4.5 Mass Balance**

For grinding under protective gas, the same conditions apply for the selection of the grinding set and grinding balls.

Two valves are screwed onto the gas lid. Before switching on the mill, you can introduce protective gas, e.g. nitrogen, through these.

A Viton flat seal is used instead of the Teflon flat seal.

### Preparation for gassing

- Fill the grinding bowl with grinding balls and the material to be ground.
- Put on the lid with seal (use Viton seal).
- Insert the grinding bowl in the grinding bowl holder.
- Clamp the grinding bowl.
- Connect the gas hose to an insert gas supply with the aid of the attached hose clip.
- Screw the de-airing fitting onto one of the two valves.
- Fit the coupling of the gas hose onto the free valve. To do so, press the lever of the coupling and push the coupling onto the valve shaft as far as it will go. Release the lever.

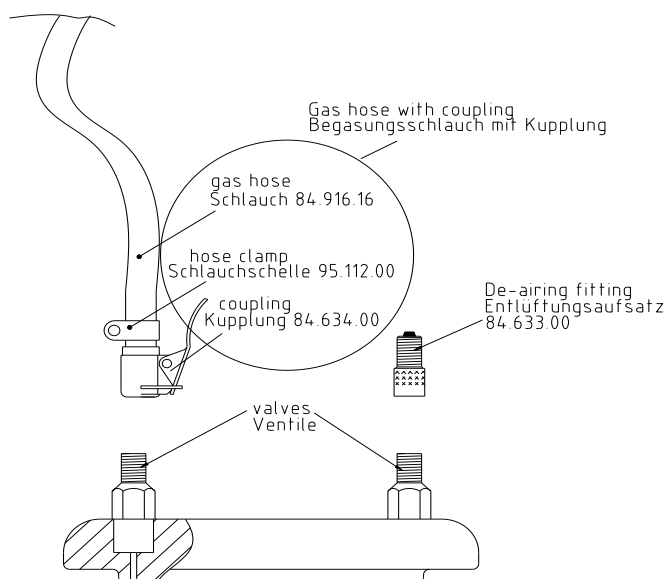

### Gassing

- Slowly open the inert gas feed.
- Press on the top of the de-airing fitting so that the air can escape from the grinding bowl.
- The inert gas will now flush the air out of the grinding bowl.
- The flushing period must be determined experimentally; the flushing period is dependent on, inter alia, the grinding bowl size, the filling and the gas feed.
- To end the flushing, close the inert gas feed and release the de-airing fitting.
- Unscrew the de-airing fitting.
- Pull off the coupling of the gas hose. For this, press the lever.

### Warning

Switch the machine on only when both the coupling and the de-airing fitting have been removed.

Excess pressure can occur during grinding.

### De-airing after grinding

- After grinding, screw on the de-airing fitting.
- For pressure equalisation, carefully press on the de-airing fitting.
- Release the grinding bowl clamping only after de-airing.

Note: Either valve can be used for airing and de-airing.

### Cleaning the valves

Both valves should be cleaned after each grinding operation.

- For this, unscrew the valve insert with the attached valve turner. Insert the thin end of the valve turner into the valve from above and turn anticlockwise.
- Unscrew the valve insert.
- Depending on the contamination, clean the valve insert with compressed air or place the valve insert in a small glass vessel filled with alcohol, clean it in the ultrasonic bath (laborette 17) and carefully dry it.
- After both valve inserts have been removed, the two valve receptacles can be cleaned from the upper side of the lid with compressed air.

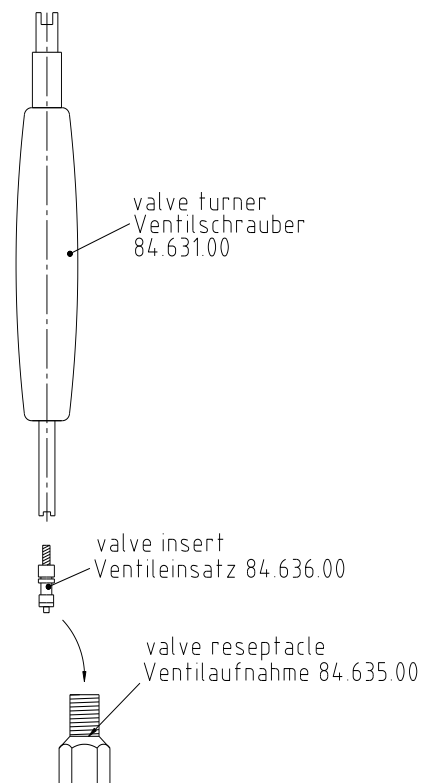

### Fitting the valve inserts

- Place the valve insert (spring pointing upwards) in the valve receptacle.
- Screw the valve insert in clockwise with the valve turner.

The following gas lids, each with two valves and a soft sealing ring, are available for the grinding sets:

Material	Order number
Hardmetal tungsten carbide 250 ml	50.8600.00
Tempered steel 80 ml	50.8700.00
Tempered steel 250 ml	50.8500.00
Tempered steel 500 ml	50.8400.00
Stainless steel 80 ml	50.8800.00
Stainless steel 250 ml	50.8300.00
Stainless steel 500 ml	50.8200.00
Agate 250 ml	50.8100.00
Agate 500 ml	50.8000.00

**The black, soft sealings made of Viton are temperature stabil up to 200°C.  
The valves are temperature stabil up to 180°C for one hour max.  
The grinding accessories made of agate are designed for temperatures up to 110°C. Then they have to be cooled down carefully and slowly.**

## 4.12 GTM System

The GTM system, order no. see price list, is available as an accessory for measuring the pressure and temperature in the grinding bowl during grinding. Instructions are provided with the GTM system.

## 5 Cleaning

### 5.1 Grinding accessories

- Clean the grinding bowl and grinding balls after each use: e.g. brush them clean under running water with usual cleaning agents.
- Fill the grinding bowl with grinding balls and some sand and water half-full and run the mill for 2 to 3 minutes (with the grinding bowl correctly clamped in position).
- Cleaning in the ultrasonic bath is permissible.
- When sterilising the grinding bowl and grinding balls in the heat cabinet, heat only to 100°C.

**Parts of agate, sintered corundum, zirconium oxide should be cooled down carefully and slowly.**

**Agate parts must never be heated in the microwave (they heat up too rapidly).**

**They must never be subjected to temperature shocks, such shocks may destroy the parts → They burst apart explosively.**

### 5.2 Mill

When switched off, the planetary monomill can be wiped down with a damp cloth.

**Do not allow any liquids to seep into the machine.**

## 6 Maintenance

**Before commencing maintenance work, disconnect the mains plug and secure the machine against being switched on again unintentionally. When maintenance work is being performed, this should be indicated with a warning sign.**



Attention! mains voltage

Regular cleaning is the most important part of maintenance of the planetary monomill.

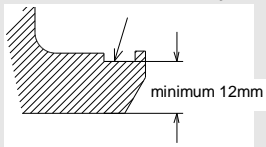
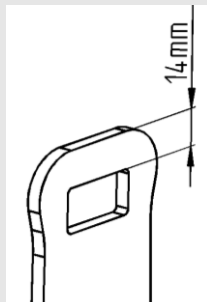
Functional part	Task / Description	Test	Maintenance interval
Safety lock	Locking the hood	Is the closed hood held shut when the main switch is off? If the test fails, you must not continue to work before the error is corrected.	Before each use
LID LOCK ACTIVATED light in the control panel	Indicates that the hood is closed	With the hood closed, the green LID LOCK ACTIVATED light must be illuminated.	1 x monthly
Rotating bearings	Permanent lubrication	Bearing play	Every 2,000 hours or annually
Drive motor	Permanent lubrication	Bearing play	Every 4,000 hours or annually
V-belt	Motor – planet disc	Check the tension Remove the housing; the belt should not yield by more than approx. 10 mm under thumb pressure.	1 x annually
Fan, Ventiduct	Cooling the grinding chamber and electronics	Operation; clean when dirty	2 x annually
Grinding bowl holder and clamping "safelock"	rubber disk of the pressure piece and rubber disk in the grinding bowl holder	Signs of use; when it has been pressed flat and is thus non-elastic, replace it	Every 1,000 hours
	indicated area of safelock worn out  height ex works 12.5mm	Safelock often was too softly tightened!! 	Every 200 hours
seal grinding bowl	grinding bowl lid seal	if dirt pressed in the sealing, replace it!	Every 100 hours
grinding bowl holder	support clamping system safelock	minimum 11mm! 	1 x annually

## **7 Warranty**

The warranty card enclosed with the machine upon delivery must be completely filled out and returned to the delivering factory so that the warranty can enter into effect.

Online registration is also possible. More information can be found on your warranty card or on our website <http://www.fritsch.de>

The company Fritsch GmbH in Idar-Oberstein and your "Technical Application Laboratory" or the corresponding national representatives would be happy to provide you with advice and assistance.

Please include the serial number given on the type plate along with any questions.

**Please note that the original Fritsch packaging must be used in the event that the machine is returned. Fritsch GmbH is not responsible for damages resulting from improper packaging (non-Fritsch packaging).**

## 8 Troubleshooting Checklist

Malfunction	Possible cause	Elimination of error
POWER SUPPLY display not illuminated	Not connected to mains	Plug in mains plug
	Main switch	Switch on the main switch
	Fuse unit at the rear of the machine	replace fuses 2x10 A T
START button pressed but mill does not start	if POWER SUPPLY display not illuminated check see above	see above
	fuse in frequency converter	replace fuse in frequency converter
	Break time active	wait for the break to end or press STOP
	safety lock was opened by hand	see chapter 2.3 Protective Devices
Mill speed reduced	if REDUCED SPEED shines: overloading	Reduce the load or accept the reduced speed
Mill stops	overheating of the drive motor	Let the mill coll down and select lower speed
	Mass balance not adequate	improve mass balance: see chapter 4.5 Mass Balance
	drive is obstructed	eliminate trouble in grinding chamber
	v-belt loosen or broken	check or change v-belt
	speed sensor defective	service to the customer
hood cannot be opened	When the hood was being opened, the button at the front of the hood was not activated	Activate the button at the front of the hood and open the hood.
	Not connected to mains	Plug in mains plug
	Main switch	Switch on the main switch
	Fuse unit at the rear of the machine	replace fuses 2 x 10 A T
Material escapes	Holder loose	check
	Sealing ring defective or dirty	Replace or clean the sealing ring
Uneven running with severe vibration	Mass balance not adequate	improve mass balance: see chapter 4.5 Mass Balance

## 9 Examples of Comminution Tasks

Material			
Quantity	Material and balls	bowl balls Qty x dia mm	Results
Edge length	Volume bowl	Grinding time	final fineness
<b>Ruby (Stone)</b>			
140 g	Cr-Ni-steel	6 x 30mm	100%
12 mm	250 ml	3 min	<250µm
<b>Titandioxid TiO<sub>2</sub> (Dry- and Wet grinding in water)</b>			
40 g	Cr-Ni-steel	6 x 30mm	100%
2 mm	250 ml	30 min	< 40µm
<b>Titandioxid TiO<sub>2</sub> (Wet grinding in water)</b>			
40g/50ml Water	Cr-Ni-steel	6 x 30mm	100%
2 mm	250 ml	60 min	< 10µm
<b>Carbon (Dry- and Wet grinding in Water)</b>			
5 g	Zirkonoxid	5 x 20mm	100%
0,5 mm	80 ml	120 min	< 15µm
<b>Aluminium oxide / Silizium oxide</b>			
100 g	WC + Co	15 x 20mm	90%
0,1 mm	250 ml	90 min	< 20µm
<b>Ferrovanadium</b>			
70 g	WC + Co	5 x 30mm	70%
3 mm	250 ml	20 min	<100µm
<b>Glass</b>			
50 g	Achat	15 x 20mm	100%
4 mm	250 ml	15 min	< 90µm
<b>Silicon carbide (Dry- and Wet grinding in Water)</b>			
15 g	WC + Co	5 x 20mm	100%
3 mm	80 ml	30 min	<150µm
<b>Silicon carbide (Dry- and Wet grinding in Water)</b>			
15g/5 ml Wasser	WC + Co	5 x 20mm	100%
3 mm	80 ml	45 min	<71µm
<b>Raw-phosphate</b>			
40 g	Cr-Stahl	15 x 20mm	100%
3mm	250 ml	2 min	<250 µm

Material			
Quantity	Material bowl and balls	balls Qty x dia mm	Results
Edge length	Volume bowl	Grinding time	final fineness
<b>Manganous oxide MnO<sub>2</sub> (Wet grinding in Water)</b>			
50g/40ml Water	WC + Co	15 x 20mm	100%
0,1 mm	250 ml	60 min	<20µm
<b>Sewage sludge (dry)</b>			
180 g	Al <sub>2</sub> O <sub>3</sub>	10 x 30mm	100%
8 mm	500 ml	30 min	<250µm
<b>Activated charcoal (Wet grinding in Water)</b>			
150 ml	Cr-Ni-Stahl	15 x 20mm	100%
0,025 mm	250 ml	30 min	< 5µm
<b>Gypsum</b>			
300 g	Cr-Stahl	10 x 30mm	100%
10 mm	500 ml	20 min	<200µm
<b>Protein</b>			
50 g	Sinterkorund 1	6 x 30mm	90%
20 mm	250 ml	90 min	< 50µm
<b>Grain (barley)</b>			
100 g	Sinterkorund 1	3 x 40mm	100%
3 mm	500 ml	20 min	< 150µm
<b>Dough</b>			
100 g	Sinterkorund 1	10 x 30mm	100%
5 mm	500 ml	3 min	< 250µm
<b>Sugar (Wet grinding in alcohol)</b>			
200 g	Achat	10 x 30mm	100%
1 mm	500 ml	45 min	< 10µm

## 10 Disclaimer

Before using this product, these operating instructions are to be carefully read and be understood. Use of the product requires expertise and it is to be carried out only by commercial users. The product may be used exclusively for the applications outlined in these instructions and within the scope of the regulations set out in these operating instructions, and it shall be subject to regular maintenance. In the event of infringements of these instructions and/or improper use or maintenance, the customer assumes full liability for the functionality of the product and for such damage or injury as may occur as a result of breaching these obligations.

The content of these operating instructions is subject as a whole to copyright protection. This operating manual and its content may not, in any form, in whole or in part, be reproduced, further distributed or saved without the prior written consent of Fritsch GmbH

These operating instructions have been compiled to the best of our knowledge and belief and checked for relevance at the time of printing. FRITSCH GMBH does not accept any warranty or guarantee for the accuracy or completeness of the content in these operating instructions, including, but not limited to, the tacit warranties of merchantability and suitability for a particular purpose, unless applicable laws or adjudications prescribe a liability.

FRITSCH GMBH expressly reserves the right to amend and/or to update these operating instructions without prior notice. The same applies to changes and improvements to the products described in these operating instructions. The onus for obtaining information about the current status of these operating instructions lies with the individual user. In this regard, please contact the FRITSCH GMBH distributor in your area or apply directly to Fritsch GmbH, Industriestrasse 8 D-55473 Idar-Oberstein, Germany.

Not all parts illustrated must be built into the product. A right to delivery of these parts does not exist. If interested in them, please contact the FRITSCH GMBH distributor in your locality or Fritsch GmbH, Industriestrasse 8, D-55743 Idar-Oberstein directly.

FRITSCH GMBH endeavours, with the greatest of care, to continually improve the quality, reliability and safety of their products and to conform with the state of the art. The products supplied, as well as these operating instructions, correspond with, at the time of transfer from the influence area of FRITSCH GMBH, the respective state of the art.

Customers agree and acknowledge that, through usage of the product, defects, faults or errors cannot be ruled out entirely. To avoid the risks thereof, of damage to persons or property being incurred, or of any other direct or indirect damages, customers must provide for adequate and comprehensive safety measures whilst working with the product.

Fritsch GmbH expressly disclaims every explicit or implied, contractual or arising from improper handling or a fixed contractual, statutory or other liability, warranty or other obligation in respect of compensation obligations. Under no circumstances shall Fritsch GmbH accept liability, resp., are you entitled to compensation, for any special, direct, indirect, incidental, or consequential damages, including but not limited to lost profits, lost savings, lost revenues or economic losses of any kind, or for compensation obligations towards third parties for downtime, goodwill, damage to or replacement of equipment and property, for the costs or restoration of materials or goods in connection with the product or the utilisation of our products, for other damage or personal injury (including death) or the like. In so far as the law or adjudications require a mandatory liability, the above disclaimer is to be considered as limited. A liability for negligence is excluded in every case.

No explicit, implied or other rights of usage are granted for patents, trademarks or other intellectual property rights. Likewise, we assume no responsibility for patent infringements or violations of the rights of third parties arising from the use of this product.

Both adherence with these operating instructions and the conditions and methods of installation, operation, usage and maintenance of the product cannot be monitored by Fritsch GmbH. Improper execution of the installation can lead to property damage and, as a result, also place people at risk. Accordingly, we accept no responsibility or liability for losses, damages or expenses resulting from, or in any way connected with, defective installation and improper operation, as well as from incorrect utilisation and maintenance.

***FRITSCH***